



2019
INSTALL & OPERATION MANUAL

EXPLORE SERIES E3



LIGHT. YEARS AHEAD.

WWW.OCEANLED.COM

OceanLED MANUAL / EXPLORE / E3 / 261119 / v9.1

Preface

READ AND FOLLOW ALL INSTRUCTIONS IN THIS MANUAL



CAUTION

(Risk Group 2): Possibly hazardous optical radiation emitted from this product. Do not stare at operating lamp. May be harmful to the eye.



WARNINGS

Before installing your OceanLED Light, read and follow all warning notices and instructions which are included. Failure to follow safety warnings and instructions can result in property damage, severe injury or even death.

Before installing your OceanLED Light, check local laws for restrictions regarding the use of coloured lights in your area.

Do not operate lights out of water for a period longer than 5 minutes followed by an OFF period of at least 1 hour. Exceeding this may cause damage to the light unit.

Ensure the bonding point of the light is fitted to the cathodic protection system on the vessel. Check conductivity between earth bonding point and aluminium bronze front bezel. If mounting the light to metal or carbon fibre hull, ensure that suitable measures have been put in place to account for the effects of galvanic corrosion i.e. use of Delrin sleeve components.

Salt is an inherently corrosive material. Metal parts and certain natural and man-made surfaces are particularly susceptible to corrosion and deterioration when used in and around salt water. Some OceanLED lights contain combinations of plastic and polymer products which are impervious to salt water corrosion, however, screws and fasteners used for the installation must be of a marine grade type stainless steel or equivalent and monitored annually to ensure the lights remain in service for years to come.

Never connect/disconnect lights with power applied as irreversible damage may occur.

Ensure lights are always fully submerged and not fitted on planing / running surfaces that may impact on water since this may damage the product.

Never Use Solvents! Cleaners, fuel, and other products that may contain strong solvents, such as acetone, that attack many plastics greatly reducing their strength and irreversibly damaging the special lens coatings and cable sheathings.



DANGER

RISK OF ELECTRIC SHOCK OR ELECTRICUTION

This underwater light must be installed by a licensed or certified electrician in accordance with all applicable local codes and ordinances. Improper installation will create an electrical hazard which could result in death or serious injury to swimmers, installers, or others due to electrical shock, and may also cause damage to property. Always disconnect the power to the light at the circuit breaker before servicing the light.

Contents

1. OVERVIEW
2. PREPARING THE HULL
3. INSTALLTION
4. OPERATION / MAINTENANCE
5. TROUBLESHOOTING
6. APPENDIX

PRETEST

Always test the lights prior to installation. Failure to do this may result in additional installation time and could invalidate the warranty.

IMPORTANT NOTICE

Attention Installer: This manual contains important information about the installation, operation and safe use of this product. This information should be given to the owner and/ or operator of this equipment.

WARRANTY COVERAGE

3 year warranty from time of purchase, regardless of installation date.
Please refer to www.oceanled.com/downloads for full warranty statement.

1

Overview

Identifying your model



Explore E3 Single Colour

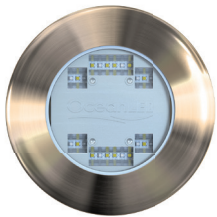

Explore E3 Dual Blue / White

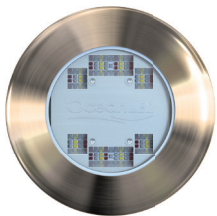

Explore E3 Multi Colour

Power Source

Most installations will utilize on-board 12/24V DC power supply from a marine battery. However, if AC to DC power supply is being used, allow at least 15% reserve for voltage fluctuations due to variables beyond your control such as ambient temperature and supply voltage fluctuations to ensure your lights are always receiving the proper voltage and to ensure the power supply is not “overloaded” causing premature failure. Use chart below in determining power supplies.

Power Consumption and Recommended Fuse Values

Model	Current @ 12V DC	Current @ 24V DC	Power consumption in Watts	15% reserve in Watts	Recommended fuse 12V/24V DC
E3 White	5.5A	2.4A	66W	76W	10A
E3 Blue	5.5A	2.4A	66W	76W	10A
E3 Dual Blue White	3.6A	1.7A	43W	50W	10A
E3 Multi Colour	5.5A	2.4A	66W	76W	10A

2 Preparing the Hull

! When installing the Explore units, please check the inside spacing to ensure that if maintenance is required, there is enough space on the inside of the boat to remove the insert. For example, the XFM unit requires an additional 85mm / 3.5" from the rear of the mounting tube to allow the insert to be removed. (See dimensions below).

Moreover, ensure that the part of the light inside the boat is free from any insulation material for at least 100mm / 4" all around it.

🔧 OceanLED recommends using a qualified installer / technician when making modifications to your vessel. Please also consult the manufacturer for more detail on modifications and installation.

DEPTH / SPACING

Ideally mount your lights at similar depth levels to ensure matching colour consistency through the water. Deeper lights will look duller and possibly differ in colour to shallower mounted units.

SPACING / INSTALL DEPTH	E3	E6
Recommended Spacing	0.5-1M (2-4')	2.5-3M (8-10')
Recommended Installation depth (From top of the waterline)	15-25CM (6-10")	15-25CM (6-10")

2.1 HOLE CUT OUT

Hole Cut out size - 83mm (3.25") / With Delrin Sleeve 89mm (3.5")

2.2 OVERALL DIMENSIONS

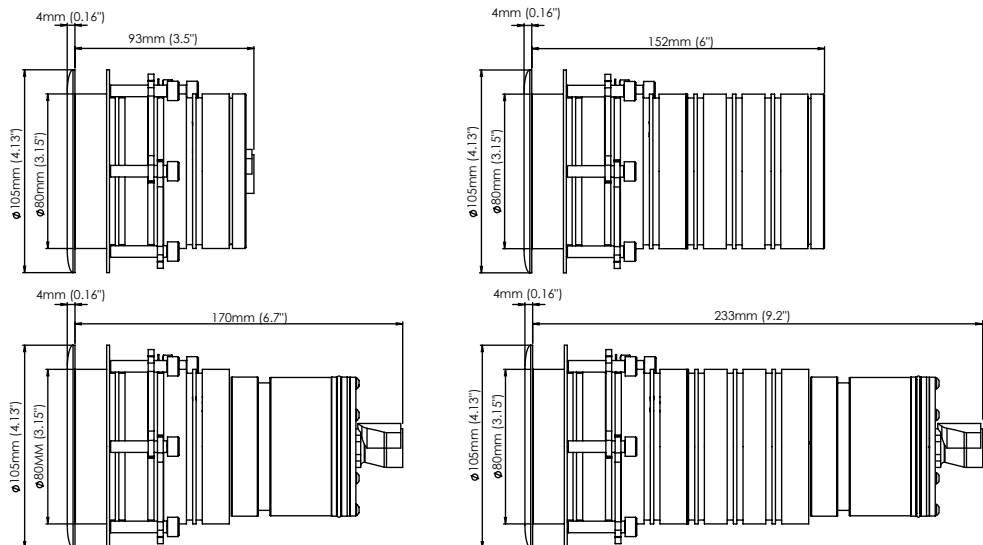

3 Installation

3.1 INSTALLING THE LIGHT FIXTURE

ADDITIONAL TOOLS NEEDED THAT ARE NOT SUPPLIED BY OCEANLED

- Marine sealant - 3M 4200 or equivalent
- Cable ties
- Waterproof Cable Connectors / Junction Box (optional)
- Allen key (5mm)
- Thread lock - Loctite 243 or equivalent.

! DO NOT remove the light cartridge from the mounting tube during installation. The light cartridge **MUST** stay fitted inside the mounting tube throughout the installation process to avoid the introduction of potential contaminants that may damage the product.

🔧 OceanLED recommends dry fitting all products. When installing, be sure that the light fits the area and secures to the hull using the appropriate hardware before applying any sealant.

🔧 When applying sealant to light fixture, use the OceanLED packaging material as a cushion when placing light on the ground face down to prevent lens damage.

INSTALLATION (Once hull preparation is complete)

1. Test lights before fitting.
2. (If using Delrin sleeve) insert the Delrin sleeve into the drilled hole and apply marine sealant to seal between the Delrin sleeve and the hull.
3. Apply sealant to rear of mounting tube assembly's bezel to ensure a complete unbroken seal around the light.

🔧 Make sure sealant fills in the recess groove on the reverse of the light bezel:

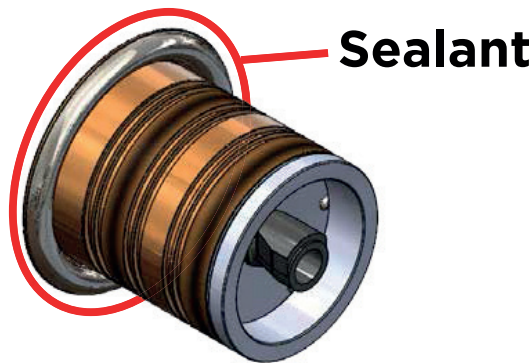

Explore E3
Kit Includes
Explore E3 Light
Power Pigtail
Locking Ring Kit
Inline Fuse Kit
Removal Tool

Installation

4. Insert the complete light unit (mounting tube assembly + light cartridge) into the hull, pressing the light hard into the hull and twist slightly to spread the sealant around behind the light to ensure good adhesion.

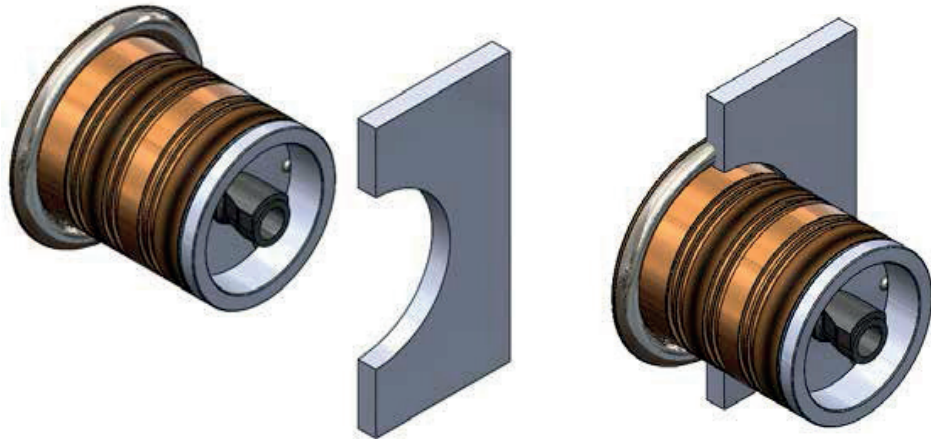

5. Ensure the light orientation is correct with the red arrow sticker on the rear lid pointing up perpendicular to the waterline.



This process is made much easier if a second person is inside the hull to receive the light and install the locking equipment whilst supporting the light from the outside. Breakages due to lights falling out of the hull are NOT covered under warranty and can cause serious bodily injury as can any falling object.

6. (If using Delrin sleeve) insert Delrin sleeve washer over mounting tube until flush with the hull.
7. Insert the stainless steel compression washer onto the mounting tube.



The stainless steel compression washer does not need to be flat to the hull, a slight uneven surface can be taken up by the washer.

Installation

7. Place the two C clips together to form a circle, ensuring you pair 1 threaded and 1 non-threaded hole together. Fix clips together using one of the screws provided so that the clips are located approximately half way down the length of the screw. Locate clips into grooves on outside of the mounting tube so that the end of the screw is close to the washer. Fit the screws provided into the remaining holes, fixing the two clips together. Leave the longer screw out to connect the light to the vessel's cathodic protection system. Screw down to the same position:



8. Tighten the locking screws using a 5mm Allen key, applying thread lock at point of thread contact with locking ring. **DO NOT** over-tighten locking screws, as you could damage the mounting tube and this will not be covered under warranty.

Once you are satisfied that the unit is fully tightened, you will notice that sealant has squeezed out from around the perimeter of the light. Using a thinner or cleaner, apply to cloth and wipe off excess sealant to leave a clean seal. **AVOID CONTACT WITH LENS.** If you do not see sealant squeeze out from the body, you have not used enough sealant or tightened the unit enough to the hull. Carefully examine the installation to make sure the seal you have installed on the unit is fully water-tight. If in doubt, remove light, re-apply sealant and re-install.

9. Connect the bonding cable to the remaining screw and lock in place with the nut and shake proof washer provided. Tighten the locking screw using a 5mm Allen key, applying thread lock at point of thread contact with locking ring.

BONDING: The light **MUST** be attached to the vessels bonding / cathodic protection system. Once fitted it is mandatory to check that there is full continuity between the vessels cathodic protection system and the outer bezel of the mounting tube assembly (see bonding schematic - chapter 6 Appendix).

Installation

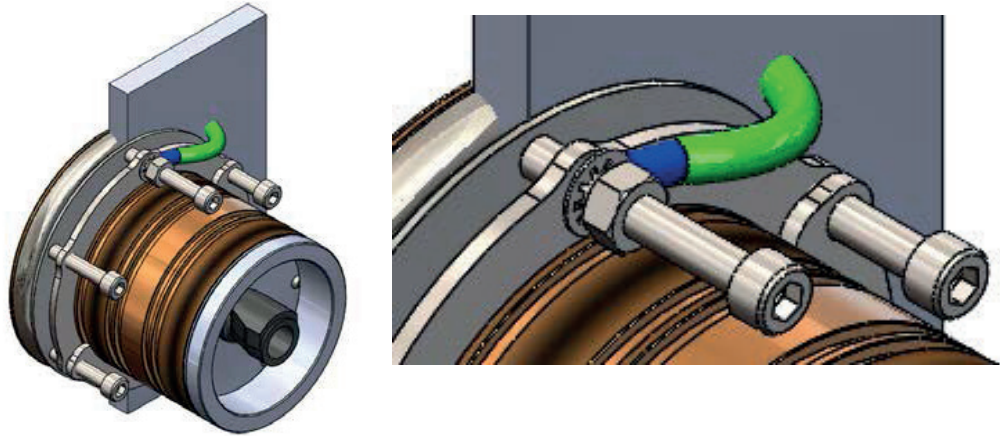

3.2 INSTALLATION (DC)

ADDITIONAL TOOLS NEEDED THAT ARE NOT SUPPLIED BY OCEANLED

- Junction box / waterproof connectors
- Sufficient cable to connect to DC power source



Always consult a qualified electrician when connecting OceanLED light fixtures.

When connecting light units, please note that all OceanLED lights will operate within a specific voltage range. Please check the electrical information to ensure cable gauge follow the recommendations.

Never leave the bare cables unprotected. Take care to not leave the bare wire ends in bilge water before making the waterproof connections. Water deposits in the connectors and cables will cause corrosion. Over time water can also work its way into the unit along the inside of the cable due to capillary action causing the light to fail. This will NOT be covered under warranty.



For complete instructions on DC connections, please refer to ABYC codes of practice and other applicable codes and ordinances for DC connections.

1. Depending on the model and number of lights installed, you will need to pull the correct sized power cable from the DC power source (breaker/fuse panel) to the light locations to supply constant power to the light units. It is imperative that the correct sized tinned marine grade cable is used to avoid voltage drop issues. See Chapter 6: Appendix for recommended cable gauges.
2. Using waterproof butt splices or IP66 waterproof junction boxes, make the connections at either end of the system to attach the lights to the DC system. Make sure any heat shrink used completely encapsulates the outer wire sheath (the use of glue-lined heat shrink is highly recommended to ensure water tightness).

Installation

- It is imperative that either the OceanLED supplied fuse on each power line to each light or a suitable protection device is used to protect the cable/light unit. Failure to do so will void the warranty. See table in Chapter 1: Overview.
- Secure cables ensuring where the cable exits the light it is not under undue stress. Finish and test the light units BEFORE the boat goes into the water.

12/24V DC Connection Diagram

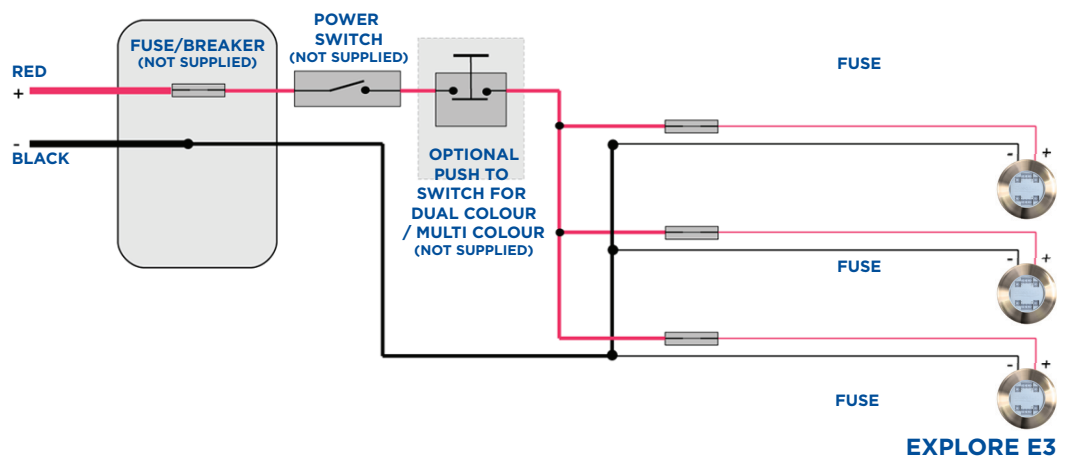

3.3 INSTALLATION OF AC POWER KIT (OPTIONAL)

ADDITIONAL TOOLS NEEDED THAT ARE NOT SUPPLIED BY OCEANLED

- Screws to secure the AC Power Pack
- Junction box / waterproof connectors
- Sufficient cable to connect to AC Power Pack
- Suitable fuse / breaker(s)



Always consult a qualified electrician when connecting OceanLED light fixtures.

Never use power tools to secure the Power Pack: hand tighten only.

When connecting light units, please note that all OceanLED lights will operate within a specific voltage range. Please check the electrical information to ensure cable gauge, fuse and breakers size follow the recommendations.

Always mount Power Pack in a dry location. Drivers should not sit in standing water at any time.



The 3 core input is for power (Brown=Live; Blue=Neutral; Green/Yellow=Earth) and the two pin Deutsch Connector is for the light.

AC Power Kit Includes

AC Power Pack

Power Link Cable

Installation

1. Depending on the model and number of lights installed, you will need to pull the correct sized power cable from the AC Power (breaker/fuse panel) to the Power Pack locations. Ensure the correct sized tinned marine grade cable is used to avoid voltage drop issues.
2. Fix Power Pack into required position. Ensure chosen Power Pack location is near enough to connect light cable without applying undue stress.

! Never leave the bare cables unprotected. Take care to not leave the bare wire ends in bilge water before making the waterproof connections. Water deposits in the connectors and cables will cause corrosion. Over time water can also work its way into the unit along the inside of the cable due to capillary action causing the light to fail. This will NOT be covered under warranty.

3. Connect the Power Pack to the AC Power. Ensure the size fuse/breaker, cable and connector have the correct specification and are watertight. Make sure any heat shrink used completely encapsulates the outer wire sheath (the use of glue-lined heat shrink is highly recommended to ensure water tightness). Leave the connection unplugged to eliminate the danger of electrocution.

! Corrosion of wire and/or water ingress into the light unit via cable is NOT covered under warranty.

4. Connect the Deutsch connector from the Power Pack to the light using the Power Link Cable.
5. Secure cables ensuring where the cable exits the light it is not under undue stress. Finish and test the light units BEFORE the boat goes into the water.

3.4 TEST YOUR INSTALLATION

Always test the lights BEFORE the boat goes back into the water. At this final stage make sure all of the system is operational. If you have any issues, please contact your local OceanLED representative.

! Never install a new light fixture then leave the boat in the water unchecked for several days.

When the boat is placed in the water, immediately check for leaks. Note that very small leaks may not be readily observed. It is best not to leave the boat in the water for more than 3 hours before checking it again. If there is a small leak, there may be considerable bilge water accumulation after 24 hours. If a leak is observed, you must take action immediately to prevent damage.

! Never connect/disconnect lights with power applied as irreversible damage may occur.

4 Operation / Maintenance

4.1 SINGLE COLOUR STROBE

To enter strobe mode, toggle the power on and off quickly twice and then back on. They should now strobe in a pseudo-random pattern. The lights can be reset from strobe mode after 20 seconds of use. Simply turn off then turn on again.

4.2 MAINTENANCE

Marine growth can build up quickly on the light and can reduce the performance in just a few weeks.

To help prevent this, all OceanLED lights have been coated with a specialized Tritonium® coating which makes the surface of the glass lens a non-stick layer. Lights should be cleaned with a boat brush or similar biweekly, or as needed to keep the lens of the light clean.

Growth varies greatly around the world and maintenance is imperative to the proper operation and longevity of the product. If heavy fouling occurs, barnacles can be removed from the lens using a plastic scraper and moderate pressure under water. If cleaning the lens while the boat is out of the water, wet the lens before scraping. Never scrape or try to remove barnacles from a dry lens. Never use high pressure jet wash to clean the lens / bezel.

4.3 LIGHT CARTRIDGE REMOVAL

 **Before proceeding with this operation, you MUST seek permission from either the manufacturer or your OceanLED representative.**

DO NOT remove the light cartridge from the mounting tube during installation. The light cartridge MUST stay fitted inside the mounting tube throughout the installation process to avoid the introduction of potential contaminants that may damage the product.

Additional tools needed that are not provided by OceanLED

- Allen key (2mm).

4.4 REMOVAL PROCESS

1. Remove the locking ring from the mounting tube.
2. Undo one of the six screws from the back of the light cartridge to allow the removal tool to be placed (see image below).

Operation / Maintenance

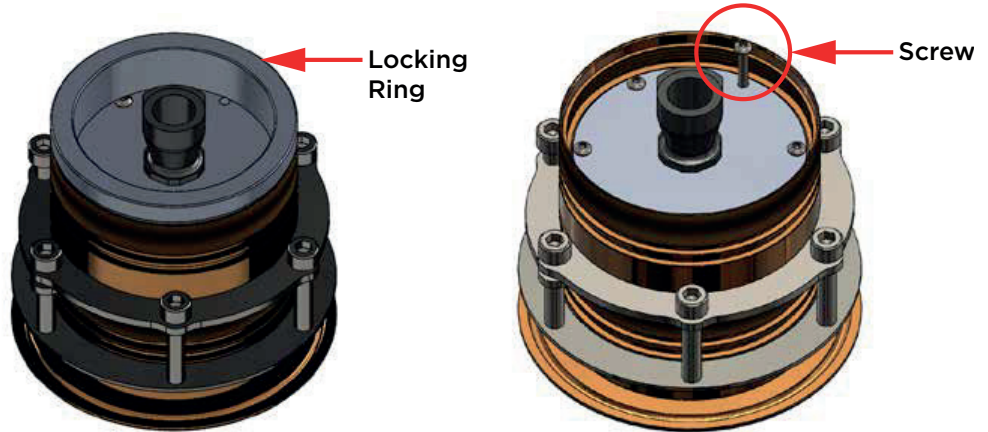

To ease the removal process, another screw can be removed to act as a breather.

3. Place the removal tool under the head of the undone screw making sure that the screw engages with the slot on the removal tool, then fasten the screw in a clockwise motion. The removal tool acts as an extractor pulling the light cartridge out of the mounting tube.

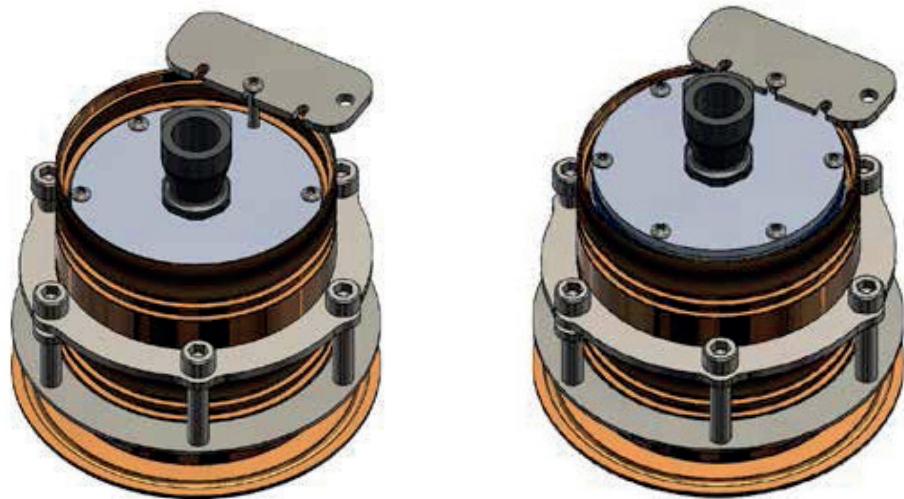

4. Pull the light cartridge out by hand with the help of the tool to fully remove it from the mounting tube.

4.5 LIGHT CARTRIDGE INSTALLATION

Additional tools needed that are not provided by OceanLED

- Allen Key (2mm)

Operation / Maintenance

! Before installing the light cartridge, clean the inside of the mounting tube with isopropyl alcohol cleaner and let it dry. Failure to do this may introduce potential contaminants that may damage the product.

Lubricant substances of any kind **MUST NEVER** be used to ease the insertion of the light cartridge into the mounting tube. Should any help to insert the light cartridge be needed OceanLED recommend the use of a small quantity of IPA (Isopropyl Alcohol) sprayed onto the O-Ring on the back of the light cartridge.

4.6 INSTALLATION PROCESS

1. Inspect the mounting tube and light cartridge to insure no contaminant (grease, debris, dirt) are present.
2. Using the 2mm Allen key, remove one of the screws on the back of the light cartridge to act as a breather. Failure to do so will make the installation process significantly harder.
3. Align the light cartridge with the mounting tube. Push the light cartridge in slowly until it bottoms against the front bezel.

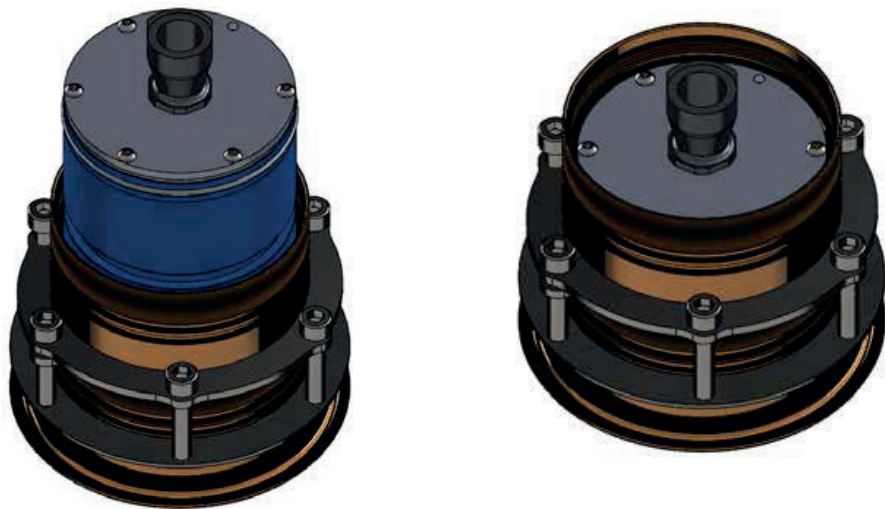

Vertically align the light before fully insert it to the mounting tube. Failure to do so will force you to remove the light cartridge. Make sure that the red arrow on the back of the light cartridge is point upwards.

4. Re-install the screw using a 2mm Allen key (hexagonal key). Re-install the locking screw making sure it is bottomed out against the light cartridge.
5. Connect the power cable and test the light. Re-check if the light is pointing the right way up.

5 Troubleshooting

5.1 TROUBLESHOOTING PROBLEMS AND THEIR SOLUTIONS

EXPLORE SERIES			
PROBLEM	CHECK	CAUSE	FIX
Light does not look bright	Check that there is no marine growth on the lens	Marine growth	Clean the lens as per maintenance advice
	Check voltage supply to the light is between 11V and 32V DC (The light will still work between 9 and 11 volts however at reduced brightness)	Voltage is either too high or too low	Investigate reason for high or low voltage and fix
	Check voltage supply is stable and does not fluctuate	Voltage is fluctuating	Investigate reason for voltage fluctuation and fix
	Check that the electrical connections between the light and the supply cable have been made correctly and recommended cable gauge has been used	Poor electrical connection	Remake connection and seal joint correctly
	Confirm all LEDs are illuminated	1 or more LEDs are not working	Contact your dealer.
	Check lights to see if water is present inside the light	Water present	Contact your dealer.
	Check cable connections for corrosion	If corrosion is present	It is not advised to reuse the cable if water is present inside. Contact your dealer for a replacement. This is NOT covered by the warranty
Light has water inside	Check integrity of lens	Light will require replacing	This is not covered by the warranty - Contact your dealer for a replacement light. Only use genuine OceanLED parts
	Check connections to make sure they are not submerged in water	Light will require replacing	This is not covered by the warranty
	Check cable to make sure there is no damage to the cable	Cable will require replacing	This is not covered by the warranty. Only use genuine OceanLED parts
	Checked all factors that are above, and the light still does not work	Light faulty	Contact your dealer for a replacement light

Troubleshooting

EXPLORE SERIES			
PROBLEM	CHECK	CAUSE	FIX
Light does not light up	Check that the electrical connections between the light and the supply cable have been made correctly	Poor electrical connection	Remake connection and seal joint correctly
	Check that the wiring polarity is correct, red to positive and black to negative	Polarity incorrect	Change the wiring polarity and seal joint correctly
	Check that there is power supply to the light cable connection	Poor electrical connection	Trace the cables back, checking at joints until break has been located. Then rectify the problem and seal joint correctly
	Check that the electrical connections between the supply cable and the light circuit breaker or fuse have been made correctly	Poor electrical connection	Remake connection and seal joint correctly
	Check that the in-line fuse is intact and not blown	Replace fuse	If fuse keeps blowing, then there is a short circuit in the light system that must be traced and rectified. If no external short can be located contact your dealer
	Exchange the interlink cable (between light and power supply) with one from a working light	Light works, faulty cable	Contact your dealer for a replacement cable
	Check that the light supply circuit breaker is closed, or the fuse has not blown	Close circuit breaker / replace fuse	If breaker / fuse keeps blowing, then there is a short circuit in the light system that must be traced and rectified. If no external short can be located contact your dealer

6 Appendix

6.1 ESSENTIAL TEST

! Perform this bonding check after installation of the light and before moving the boat back into the water.

Refer to bonding information in the installation sections in this manual. If in doubt, please contact OceanLED.

1. Connect the light assembly to the cathodic protection system as explained in Chapter 3.
2. Measure the electrical continuity between the front bezel and the sacrificial anode. This test should give a reading of up to 0.5 Ω (Ohms). This procedure will guarantee electrical continuity between the front bezel, the mounting tube and sacrificial anode.

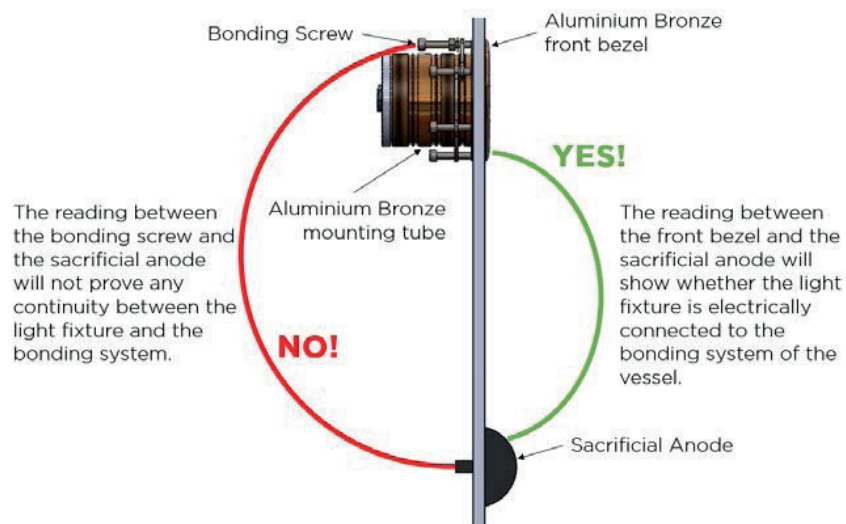

If you have any questions regarding the above, please contact OceanLED: +44 (0) 1455 637505 or info@oceanled.com

Appendix

6.2 CABLE GAUGE CHART 12V

Supply & Return Cable Conductor Size Chart 3% drop for when using 12V DC supply

Cable length (feet)*	Circuit Current										
	2 Amp	4 Amp	6 Amp	8 Amp	10 Amp	15 Amp	20 Amp	25 Amp	30 Amp	40 Amp	50 Amps
0-5	18 AWG	18 AWG	16 AWG	16 AWG	14 AWG	12 AWG	12 AWG	10 AWG	10 AWG	8 AWG	8 AWG
5-10	18 AWG	16 AWG	14 AWG	12 AWG	12 AWG	10 AWG	8 AWG	8 AWG	6 AWG	6 AWG	4 AWG
10-15	16 AWG	14 AWG	12 AWG	10 AWG	10 AWG	8 AWG	6 AWG	6 AWG	4 AWG	4 AWG	2 AWG
15-20	16 AWG	12 AWG	10 AWG	10 AWG	8 AWG	6 AWG	6 AWG	4 AWG	4 AWG	2 AWG	2 AWG
20-25	14 AWG	12 AWG	10 AWG	8 AWG	8 AWG	6 AWG	4 AWG	4 AWG	2 AWG	2 AWG	1 AWG
25-30	14 AWG	10 AWG	10 AWG	8 AWG	6 AWG	4 AWG	4 AWG	2 AWG	2 AWG	1 AWG	0 AWG
30-35	14 AWG	10 AWG	8 AWG	8 AWG	6 AWG	4 AWG	4 AWG	2 AWG	2 AWG	1 AWG	0 AWG
35-40	12 AWG	10 AWG	8 AWG	6 AWG	6 AWG	4 AWG	2 AWG	2 AWG	1 AWG	0 AWG	0/2 AWG
40-45	12 AWG	10 AWG	8 AWG	6 AWG	4 AWG	4 AWG	2 AWG	2 AWG	1 AWG	0 AWG	0/2 AWG
45-50	12 AWG	8 AWG	6 AWG	6 AWG	4 AWG	2 AWG	2 AWG	1 AWG	0 AWG	0/2 AWG	0/3 AWG
50-55	12 AWG	8 AWG	6 AWG	6 AWG	4 AWG	2 AWG	2 AWG	1 AWG	0 AWG	0/2 AWG	0/3 AWG
55-60	10 AWG	8 AWG	6 AWG	4 AWG	4 AWG	2 AWG	1 AWG	0 AWG	0 AWG	0/3 AWG	0/4 AWG
60-65	10 AWG	8 AWG	6 AWG	4 AWG	4 AWG	2 AWG	1 AWG	0 AWG	0/2 AWG	0/3 AWG	0/4 AWG
65-70	10 AWG	8 AWG	6 AWG	4 AWG	4 AWG	2 AWG	1 AWG	0 AWG	0/2 AWG	0/3 AWG	0/4 AWG
70-75	10 AWG	6 AWG	4 AWG	4 AWG	2 AWG	2 AWG	0 AWG	0/2 AWG	0/2 AWG	0/4 AWG	
75-80	10 AWG	6 AWG	4 AWG	4 AWG	2 AWG	1 AWG	0 AWG	0/2 AWG	0/3 AWG	0/4 AWG	
80-85	10 AWG	6 AWG	4 AWG	4 AWG	2 AWG	1 AWG	0 AWG	0/2 AWG	0/3 AWG	0/4 AWG	
85-90	10 AWG	6 AWG	4 AWG	4 AWG	2 AWG	1 AWG	0 AWG	0/2 AWG	0/3 AWG	0/4 AWG	
90-95	8 AWG	6 AWG	4 AWG	2 AWG	2 AWG	1 AWG	0/2 AWG	0/3 AWG	0/3 AWG		
95-100	8 AWG	6 AWG	4 AWG	2 AWG	2 AWG	0 AWG	0/2 AWG	0/3 AWG	0/4 AWG		

*One-way cable length from supply (usually battery) to load.

6 Appendix

6.3 CABLE GAUGE CHART 24V

Supply & Return Cable Conductor Size Chart 3% drop for when using 24V DC supply

Cable length (feet)*	Circuit Current										
	2 Amp	4 Amp	6 Amp	8 Amp	10 Amp	15 Amp	20 Amp	25 Amp	30 Amp	40 Amp	50 Amps
0-5	18 AWG	18 AWG	18 AWG	18 AWG	18 AWG	16 AWG	14 AWG	14 AWG	12 AWG	12 AWG	10 AWG
5-10	18 AWG	18 AWG	16 AWG	16 AWG	14 AWG	12 AWG	12 AWG	10 AWG	10 AWG	8 AWG	8 AWG
10-15	18 AWG	16 AWG	14 AWG	14 AWG	12 AWG	12 AWG	10 AWG	8 AWG	8 AWG	6 AWG	6 AWG
15-20	18 AWG	16 AWG	14 AWG	12 AWG	12 AWG	10 AWG	8 AWG	8 AWG	6 AWG	6 AWG	4 AWG
20-25	18 AWG	14 AWG	12 AWG	12 AWG	10 AWG	8 AWG	8 AWG	6 AWG	6 AWG	4 AWG	4 AWG
25-30	16 AWG	14 AWG	12 AWG	10 AWG	10 AWG	8 AWG	6 AWG	6 AWG	4 AWG	4 AWG	2 AWG
30-35	16 AWG	14 AWG	12 AWG	10 AWG	10 AWG	8 AWG	6 AWG	6 AWG	4 AWG	4 AWG	2 AWG
35-40	16 AWG	12 AWG	10 AWG	10 AWG	8 AWG	6 AWG	6 AWG	4 AWG	4 AWG	2 AWG	2 AWG
40-45	14 AWG	12 AWG	10 AWG	10 AWG	8 AWG	6 AWG	4 AWG	4 AWG	4 AWG	2 AWG	2 AWG
45-50	14 AWG	12 AWG	10 AWG	8 AWG	8 AWG	6 AWG	4 AWG	4 AWG	2 AWG	2 AWG	1 AWG
50-55	14 AWG	12 AWG	10 AWG	8 AWG	8 AWG	6 AWG	4 AWG	4 AWG	2 AWG	2 AWG	1 AWG
55-60	14 AWG	10 AWG	10 AWG	8 AWG	6 AWG	4 AWG	4 AWG	2 AWG	2 AWG	1 AWG	0 AWG
60-65	14 AWG	10 AWG	8 AWG	8 AWG	6 AWG	4 AWG	4 AWG	2 AWG	2 AWG	1 AWG	0 AWG
65-70	14 AWG	10 AWG	8 AWG	8 AWG	6 AWG	4 AWG	4 AWG	2 AWG	2 AWG	1 AWG	0 AWG
70-75	12 AWG	10 AWG	8 AWG	6 AWG	6 AWG	4 AWG	2 AWG	2 AWG	2 AWG	0 AWG	0/2 AWG
75-80	12 AWG	10 AWG	8 AWG	6 AWG	6 AWG	4 AWG	2 AWG	2 AWG	1 AWG	0 AWG	0/2 AWG
80-85	12 AWG	10 AWG	8 AWG	6 AWG	6 AWG	4 AWG	2 AWG	2 AWG	1 AWG	0 AWG	0/2 AWG
85-90	12 AWG	10 AWG	8 AWG	6 AWG	4 AWG	4 AWG	2 AWG	2 AWG	1 AWG	0 AWG	0/2 AWG
90-95	12 AWG	8 AWG	8 AWG	6 AWG	4 AWG	4 AWG	2 AWG	1 AWG	1 AWG	0/2 AWG	0/2 AWG
95-100	12 AWG	8 AWG	6 AWG	6 AWG	4 AWG	2 AWG	2 AWG	1 AWG	0 AWG	0/2 AWG	0/3 AWG

*One-way cable length from supply (usually battery) to load.

Warranty

Please remove this page and keep for your files

**For technical assistance:
Europe: service@oceanled.com**

The Americas: warranty@oceanledusa.com

Warranty Serial Code(s):

**© 2019 Ocean LED Marine LTD
All Rights Reserved**

Specifications are subject to change without notice.

Trademarks are the property of Ocean LED Marine LTD



Ocean LED Marine LTD

Unit 1 Jacknell Road
Dodwells Bridge Industrial Estate
Hinckley,
Leicestershire LE10 3BS
United Kingdom

Tel: +44 (0) 1455 637505
Fax: +44 (0) 1455 238553
sales@oceanled.com

Ocean LED USA LLC

778 South Military Trail
Deerfield Beach
Florida
FL 33442-3025
USA

Tel: +1 954.523.2250
Fax: +1 954.523.2249
sales@oceanledusa.com

www.oceanled.com